

**CONSERVATION AREA
CEDAR POST DETAIL**
(NOT TO SCALE)

NOTES:

1. PROPERTY LINE, STREET LINE AND OWNER INFORMATION WERE COMPILED FROM RECORDS ON FILE AT THE PLYMOUTH COUNTY REGISTRY OF DEEDS.
2. TOPOGRAPHY SHOWN ON THIS PLAN IS BASED ON THE GROUND SURVEY BY GRADY CONSULTING, L.L.C. ON MARCH 14, 2024.
3. SUBJECT SITE IS IN THE RESIDENCE A DISTRICT AS DEPICTED ON THE TOWN OF HANOVER ZONING MAP.
4. EXISTING UTILITIES, WHERE SHOWN, HAVE BEEN COMPILED BASED ON OBSERVED ABOVE GROUND EVIDENCE ONLY AND ARE TO BE CONSIDERED APPROXIMATE. GRADY CONSULTING, L.L.C. DOES NOT GUARANTEE THE LOCATION OF THE UNDERGROUND UTILITIES SHOWN OR THAT ALL EXISTING UTILITIES AND/OR SUBSURFACE STRUCTURES ARE SHOWN.

FLOOD NOTE:

BY GRAPHIC PLOTTING ONLY, THIS PROPERTY IS LOCATED IN ZONE X AS DEPICTED ON FLOOD INSURANCE RATE MAP, COMMUNITY PANEL No. 25023C 0202K, WHICH BEARS AN EFFECTIVE DATE OF JULY 6, 2021

ZONING DATA

DISTRICT: RESIDENCE A & AQUIFER PROTECTION ZONE

MINIMUM REQUIREMENTS:

LOT AREA	30,000 S.F.*
LOT FRONTAGE	150 FT
FRONT YARD	50 FT
SIDE YARD	20 FT
REAR YARD	40 FT
BUILDING HEIGHT	35 FT
MAX LOT COVERAGE	30%

*60,000 FOR AQUIFER PROTECTION ZONE

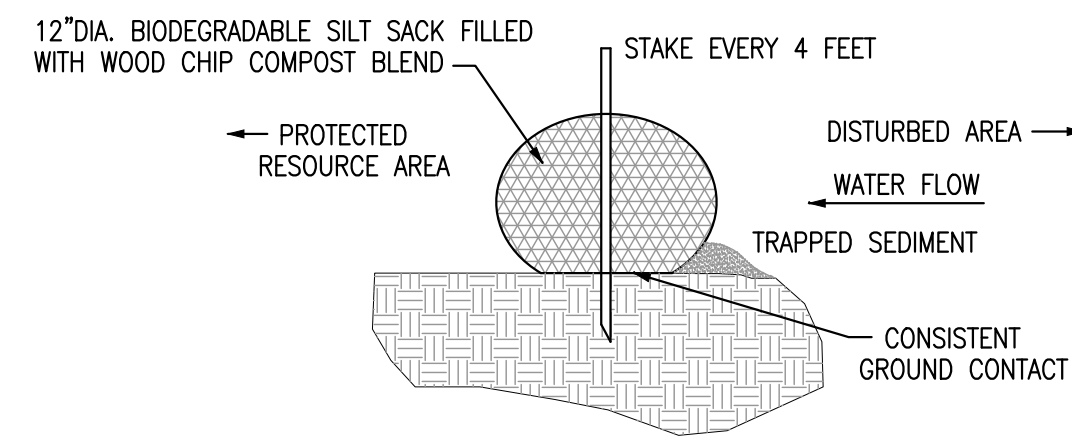

SILT SACK DETAIL
(NOT TO SCALE)

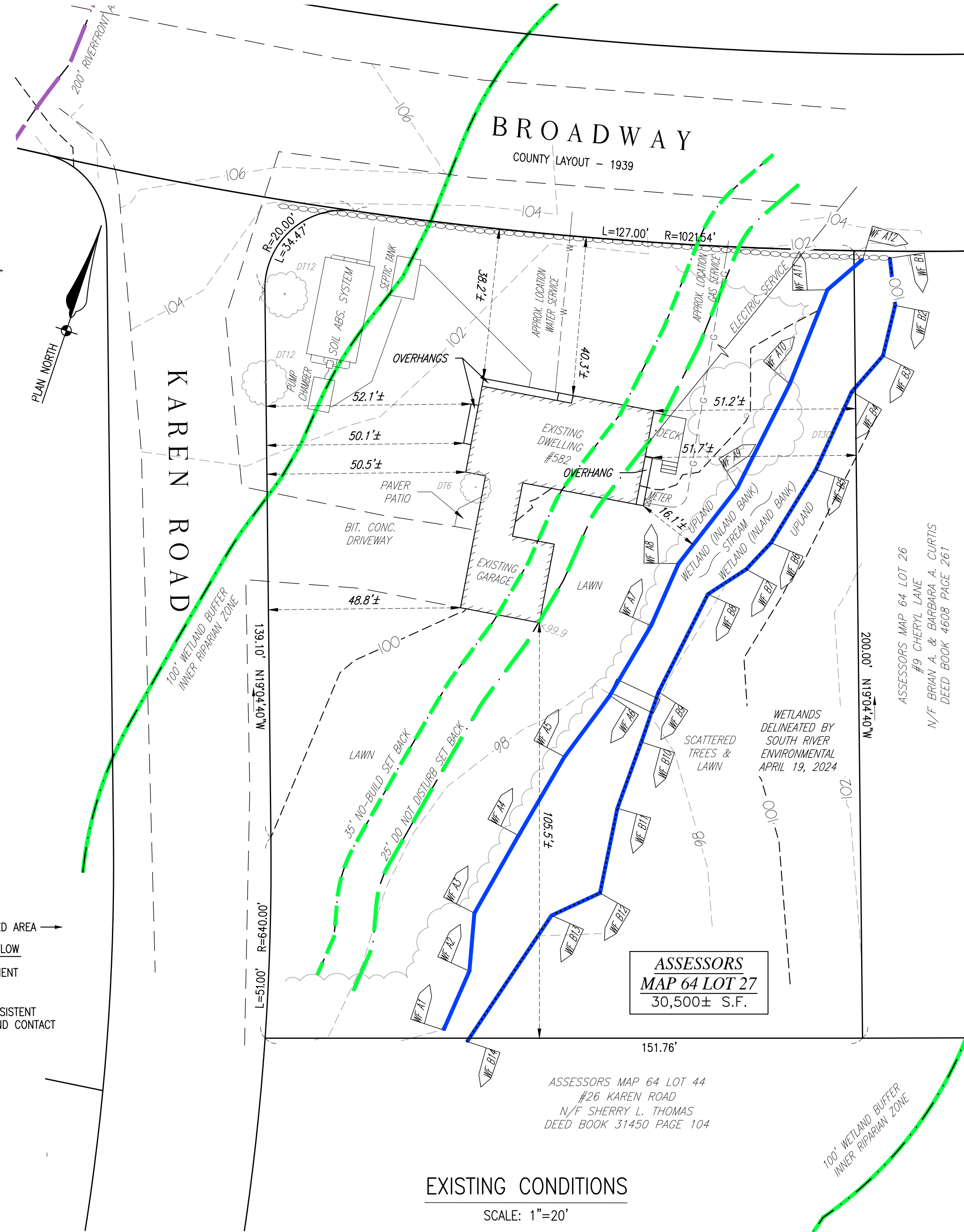

EXISTING CONDITIONS
SCALE: 1"=20'



PROPOSED CONDITIONS
SCALE: 1"=20'

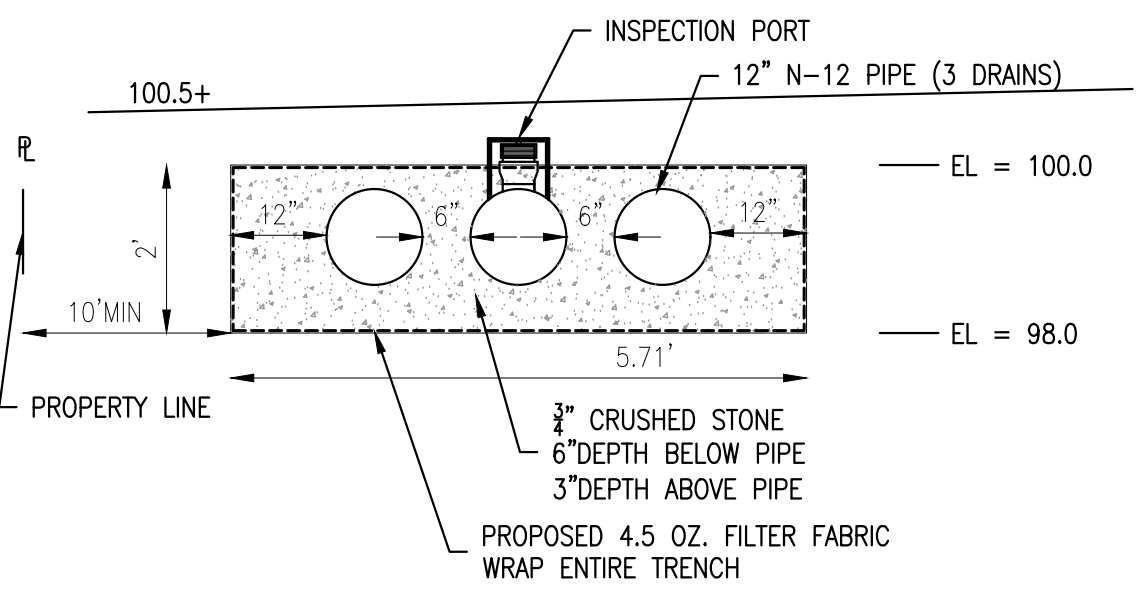

PROPOSED DRAIN SYSTEM
1 CHAMBERS/ROW X 20.00' LONG = 20.00' ROW LENGTH +12.0" END STONE X 2 = 22.00' BASE LENGTH
3 ROWS X 14.5" WIDE + 0.5" SPACING X 2 + 12.0" SIDE STONE X 2 = 5.71" BASE WIDTH
6.0" STONE BASE + 14.5" CHAMBER HEIGHT + 3.0" STONE COVER = 1.96' FIELD HEIGHT

DRY WELL FOR ROOF DRAINS
(NOT TO SCALE)

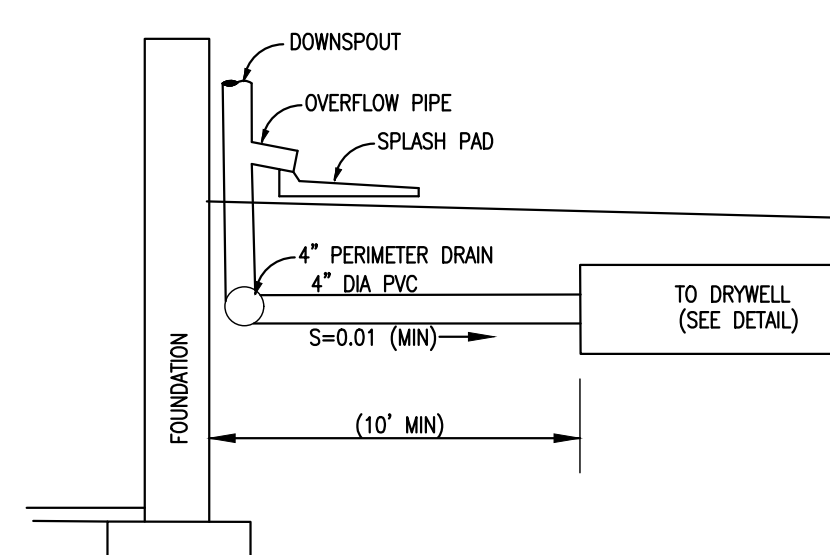

ROOF LEADER DETAIL
(NOT TO SCALE)

PLANT SCHEDULE

CODE	QTY	BOTANICAL / COMMON NAME	SIZE	SIZE	SPACING
SHRUBS					
AME CAN	3	AMELANCHIER CANADENSIS / SHADBLOW SERVICEBERRY MULTITRUNK	B & B	3-4' HGT.	
CLE ALN	10	CLETHRA ALNIFOLIA / SUMMERSWEET CLETHRA	3 GAL	15-18" HGT.	
ILE GL2	3	ILEX GLABRA / INKBERRY HOLLY	B & B	24-30" HGT.	
VAC HIG	8	VACCINIUM CORYMBOSUM / HIGHBUSH BLUEBERRY	5 GAL		
GROUND COVERS					
NE CON	909 SF	N.E. CONSERVATION / WILDLIFE MIX / LOAM, FINE GRADE & SEED	SEED		

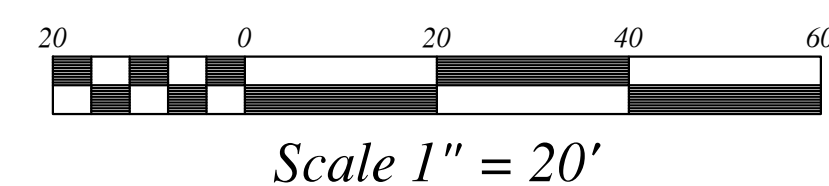

Scale 1" = 20'

RECORD OWNER:
ASSESSORS MAP 64 LOT 27

KATHERINE CROWLEY
582 BROADWAY
HANOVER, MA 02339
DEED BOOK 46270 PAGE 192
LOT 21 - PLAN #226 OF 1956

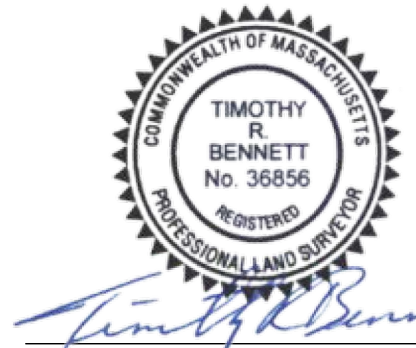
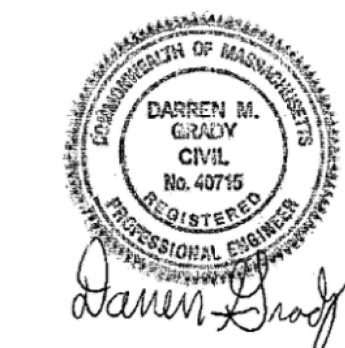

PLOT PLAN FOR ADDITION
#582 BROADWAY
HANOVER, MASSACHUSETTS
ASSESSORS MAP 64 LOT 27

PREPARED FOR:
KATHERINE E. CROWLEY
582 BROADWAY
HANOVER, MA 02339

MAY 14, 2024
SCALE: 1"=20'
JOB No. 24-078

GRADY CONSULTING, L.L.C.
Civil Engineers, Land Surveyors & Landscape Architects
71 Evergreen Street, Suite 1, Kingston, MA 02364
Phone (781) 585-2300